



Seating Pricing and Specification Guide

Price Guide - US

Prices effective January 2007



Humanscale designs and manufactures products for the workplace that directly impact the user's health and comfort.

Since our founding in 1982, we have held the belief that design based on functionality and ease of use results in honest and enduring forms.

Other Humanscale price guides also available:



Ergo Tools

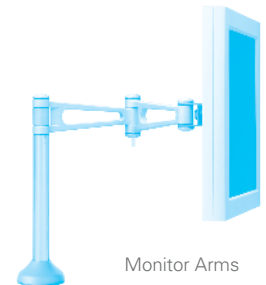

Monitor Arms

For the most updated information on available Humanscale products, please visit www.humanscale.com

Table of Contents

Our Environmental Commitment 2

Liberty[®]

Features & Characteristics 4
Options & Prices 6
Specifications 8
Build Your Product Code 9

freedom[®]

Features & Characteristics 10
Options & Prices 12
Specifications 14
Build Your Product Code 16

Textiles Program 17
Terms & Conditions 20

Our Environmental Commitment

Humanscale is committed to environmental sustainability and continually strives to design, engineer and manufacture products that, compared to all others in the same class, consume less of the Earth's limited resources. This is accomplished by creating products that weigh less (i.e., require less material), have fewer parts (i.e., require fewer manufacturing processes), contain a high percentage of recycled content (i.e., to reuse what's been used before), and contain a high percentage of recyclable content (i.e., so the material can be used again).

In addition, wherever possible, Humanscale utilizes aluminum as its material of choice. Our aluminum is 100% recycled and recyclable. It never degrades so that it can be reused over and over again. And because recyclers are paid a premium for aluminum scrap, we believe that the aluminum in our products will almost surely be recycled when the time comes. Using aluminum usually costs us more than plastics or other alternatives. But our products are better for it. And so is the environment.



Freedom, Liberty and the Environment

Freedom's Environmental Highlights

- Made predominantly of aluminum, followed by steel and plastic
- Contains 62% recycled content (43% post-consumer, 19% post-industrial)
- 90% recyclable
- Weighs only 35 lbs.
- Made of 132 parts (*comparable chairs are made of up to 250 parts*)
- Modular cushions for easy replacement
- Designed for easy disassembly
- Ships in 40% recycled packaging, or blanket-wrapped when feasible
- Greenguard Certified

Liberty's Environmental Highlights

- Made predominantly of aluminum, followed by plastic and steel
- Contains 54% recycled content (32% post-consumer, 22% post-industrial)
- 93% recyclable
- Weighs only 27 lbs.
- Modular cushions for easy replacement
- Designed for easy disassembly
- Ships in 40% recycled packaging, or blanket-wrapped when feasible
- Greenguard Certified

Freedom, Liberty and LEED-CI® Certification

Both Freedom and Liberty can help a project earn points toward LEED-CI Certification in the following areas:

Credit 4.1 (1 Point) – Recycled Content (10%)

Credit 4.2 (1 Point) – Recycled Content (20%)

Credit 4.5 (1 Point) – Low-emitting Materials

Credit 5.1 (1 Point) – Regionally manufactured within 500 miles of Piscataway, NJ

This brochure is printed in the USA on Fine Finch, paper certified by Smartwood as a well-managed source of wood products whose forest management practices adhere to strict environmental and socioeconomic standards in accordance with the criteria of the Forest Stewardship Council (FSC). Smartwood is a program of the Rainforest Alliance.



Liberty® Features & Characteristics

Liberty, with Form-Sensing Mesh Technology, is unlike any mesh chair you've seen or experienced. With its tri-panel construction, Liberty has the body-fitting contours that single-panel stretch mesh chairs simply can't achieve. And it offers perfect lumbar support for everyone, without external devices or manual adjustments. Liberty's mesh back is formed by combining three panels of low-stretch mesh in the same way a tailor combines multiple pieces of material to form a shirt. So its contours are custom-made to both fit and support the human body in unprecedented comfort.



PHYSICAL CHARACTERISTICS

CUSHIONS

- Low-stretch, tri-panel mesh back
- Molded polyurethane foam seat cushion
- Urethane Armrests
- Optional armrests and seats have top layer of Technogel®
- Seats upholstered with a variety of materials customized to the unique form of the cushion

CUSHION PAN, BACK FRAME, 5-ARM BASE

- Injection molded, structural, integral color plastics
- Optional stainless steel caps on base

EXTERNAL FRAME

- Die cast aluminum with fused plastic coating or polished aluminum finish

STORED ENERGY DEVICES

- Nitrogen charged gas cylinder for infinitely adjustable seat height
- Coil spring in the Self-Adjusting Recline mechanism
- Torsion spring in the Pivoting Backrest

FOOT RING

- Chrome-plated steel

STANDARD FEATURES

SELF-ADJUSTING RECLINE

- Intelligent counter-balance recline mechanism automatically provides the right amount of support through the full range of recline motion, regardless of user size and weight
- No tension springs to adjust
- No recline locks to set/release
- During recline, the angle between torso and legs opens up for better body function
- User maintains near constant eye level during recline

PIVOTING BACKREST

- Extra motion of the backrest during recline automatically adjusts to the changing needs of the spine
- Provides additional lumbar support as needed

FORM-SENSING MESH

- Tri-panel, low-stretch mesh construction creates body-fitting contours and self-adjusting lumbar support for a customized fit
- No external lumbar devices to adjust, break or lose
- Low-abrasion mesh protects clothing
- Modular for easy replacement

STANDARD CYLINDER

- Provides seat height range that accommodates 95% of the population

CONTOURED SEAT CUSHION

- Carefully sculpted to match body contours
- Increased contact area reduces pressure points
- Modular for easy replacement

BODY FIT

- Size adjustable to fit over 95% of the population
- Form-sensing mesh provides perfect lumbar support – automatically.
- Manual adjustments for Fit-to-Size:
 - Seat Height
 - Seat Depth

CASTERS

- 3" dual-surface casters roll easily on carpeted floors and quietly on hard floors

OPTIONAL FEATURES

ARMREST OPTIONS

- Armless
- Fixed armrests
- Height-adjustable armrests with 5" range of adjustment

GEL SEAT CUSHION

- Non-degradable, non-compressible Technogel® layer on top of foam core
- Provides maximum pressure distribution
- Offers unmatched, long-term comfort

ARM PAD OPTIONS

- Flexible urethane cover
- Technogel® arm pad for optimal comfort

CYLINDER OPTIONS

- Low range cylinder for small users
- Tall range cylinder for very tall users
- High range cylinder with foot ring for use as high chair
- Return to height cylinder returns chair to highest position when user exits chair

FIRE PROOFING

- Cal 133 approved
- Fire proof barrier between textile and foam
- Fire retardant plastics

CASTER OPTIONS

- Non-rolling glides for fixed location use

POLISHED BASE CAPS

- Stainless steel caps on five-star base for wear protection and aesthetic appeal

Liberty® Options & Prices

CONFERENCE CHAIR



Armless



Fixed Arms

OPTIONS

Armless

Fixed Arms with Urethane Cover

Fixed Gel Arms with Xanium Cover

Fixed Gel Arms with Matching Textile Cover

TASK CHAIR



Adjustable
Arms

Height Adjustable Gel Arms with Xanium Cover

Height Adjustable Gel Arms with Matching Textile Cover

SIDE CHAIR



Armless

Fixed Arms with Urethane Cover

Fixed Arms with Xanium Cover

REPLACEMENT / RETROFIT PARTS

LIBERTY CONFERENCE/TASK

Replacement Cushions

Seat (Foam)

Seat (Gel)

Mesh Back Rest

Fixed Armrest (Urethane, Pair)

Fixed Armrest (Gel, Specify Left or Right)

Adjustable Armrest (Gel, Specify Left or Right)

OPTIONS

LIBERTY SIDE CHAIR

Replacement Cushions

Mesh Back Rest

Mesh Seat Cushion

Armrest (Urethane, Pair)

Armrest (Xanium, Specify Left or Right)

Retrofit Armrest Kits



Fixed Arms with Urethane Cover (Conference/Task Chair)

Fixed Gel Arms (Conference/Task Chair)

Fixed Arms with Urethane Cover (Side Chair)

Fixed Arms with Xanium Cover (Side Chair)

Height Adjustable Gel Arms (Conference/Task Chair)

CODE	TEXTILE 1	TEXTILE 2	TEXTILE 3	LEATHER 0	LEATHER 1	LEATHER 2
L110	\$885	\$910	\$955	\$1045	\$1275	\$1470
L115	\$965	\$990	\$1035	\$1125	\$1355	\$1550
L116	\$985	\$1010	\$1055	\$1145	\$1375	\$1570
L117	\$1000	\$1030	\$1080	\$1175	\$1410	\$1610
L111	\$1055	\$1080	\$1125	\$1215	\$1445	\$1640
L112	\$1070	\$1100	\$1150	\$1245	\$1480	\$1680
L400	\$465	—	—	—	—	—
L405	\$525	—	—	—	—	—
L406	\$545	—	—	—	—	—
CODE	TEXTILE 1	TEXTILE 2	TEXTILE 3	LEATHER 0	LEATHER 1	LEATHER 2
LS	1 2 2 2 \$80	\$105	\$150	\$255	\$480	\$675
LSG	1 2 2 2 \$150	\$175	—	—	—	—
LB	4 5 2 2 \$125	—	—	—	—	—
LUA	4 \$30	—	—	—	—	—
LGA	1 2 2 2 3 \$30 (Xanium) \$40 (fabric)	\$50	\$50	\$55	\$65	\$80
LGV	1 2 2 2 3 \$30 (Xanium) \$40 (fabric)	\$50	\$50	\$55	\$65	\$80
1 – Textile (W,V,X,Z,L,P,U,D,E) 2 – Textile/Mesh Color 3 – Armrest Position (L=Left, R=Right) 4 – Frame Color (B, V, L, A, P) 5 – Mesh (M, L, T)						
LSCB	4 5 2 2 \$125	—	—	—	—	—
LSCS	4 5 2 2 \$125	—	—	—	—	—
LSUA	4 \$30	—	—	—	—	—
LSGA	4 3 \$30	—	—	—	—	—
2 – Mesh Color 3 – Armrest Position (L=Left, R=Right) 4 – Frame Color (B, V, L, A, P) 5 – Mesh (M, L, T)						
LKFU	4 \$90	—	—	—	—	—
LKFG	4 1 2 2 2 \$110 (Xanium) \$125 (fabric)	\$140	\$145	\$150	\$170	\$200
LSKFU	4 \$80	—	—	—	—	—
LSKFX	4 \$100	—	—	—	—	—
LKA	4 1 2 2 2 \$180 (Xanium) \$195 (fabric)	\$210	\$215	\$220	\$240	\$270
1 – Textile (W,V,X,Z,L,P,U,D,E) 2 – Textile Color 4 – Frame Color (B, V, L, A, P)						

Liberty® Specifications

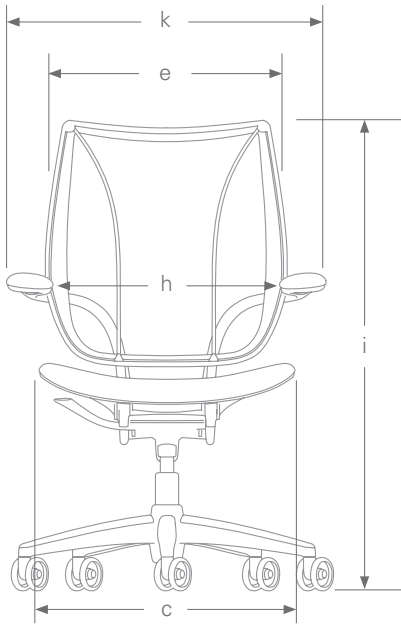

CODE	DESCRIPTION	MEASUREMENT	
		Conference/Task	Side
a	seat depth <i>(from face of lumbar to front of seat)</i>	16.5" – 18.75"	17.5"
b	seat height <i>(from floor to compressed front center of seat cushion)</i>	16" – 21" standard chair 15.25" – 19" low chair 17" – 22.25" tall chair 20.5" – 28.5" high chair with foot ring	18"
c	seat width	21"	20.75"
d	backrest height <i>(from seat cushion to top of backrest)</i>	22.5"	18.5"
e	backrest width	20"	19.75"
f	armrest height <i>(compressed seat cushion to top of armrest)</i>	10" fixed 6.5" – 11.5" adjustable	9.5"
g	armrest length <i>(from face of lumbar to front of armrest)</i>	12.25"	12"
h	distance between armrests	19"	19.25"
i	height	38.5" – 43.5" standard chair 37.75" – 41.5" low chair 39.5" – 44.75" tall chair 43" – 51" high chair with foot ring	35.5"
j	base diameter	25"	N/A
k	chair width	26.5"	24.75"

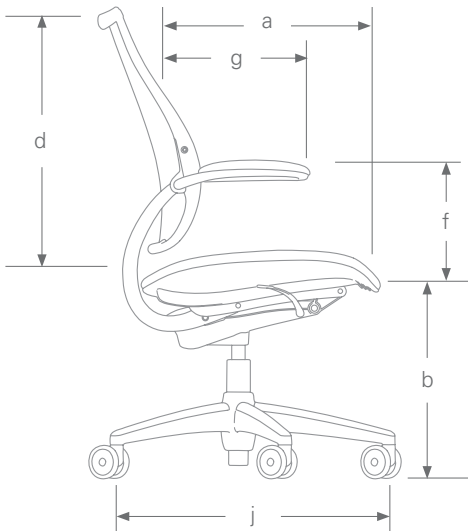

SCOPE OF USERS

- Conference/Task chair fits over 95% of the office population
 - 5'0" Woman to 6'4" Man
 - 100 to 250 pounds
- Users outside the standard range can be accommodated by
 - Low or Tall Cylinder Height

WEIGHT

- 27 lbs. *Conference/Task chair*
- 15 lbs. *Side chair*

DUAL ACTION RECLINE

- 17° recline plus 7° backrest tilt
Conference/Task chair

REFERENCE ANGLE BETWEEN SEAT AND BACK

- 100° to 124° *Conference/Task chair*

Liberty® Build Your Product Code

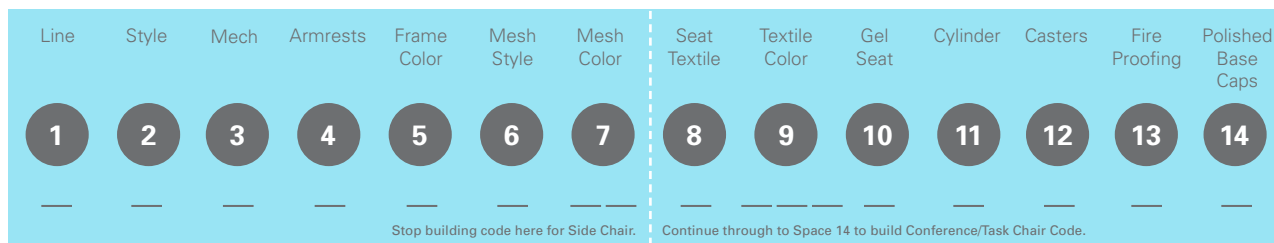

CHARACTER	CODE	DESCRIPTION	CHARACTER	CODE	DESCRIPTION
1	LINE	L Liberty	8	SEAT TEXTILE	W Wave V Vellum U Spirit Millennium D Sensuede Z Vicenza Leather L Sabrina Leather
2	STYLE	1 Conference/Task 4 Side Chair	9	TEXTILE COLOR	See pages 17-18 and Textiles Kit for color options and codes.
3	MECHANISM	0 Side Chair 1 Conference/Task	10	GEL SEAT	— Standard Seat Pan G Gel Seat (Add \$70) (Available only with Wave and Vellum textiles)
4	ARMRESTS	0 Armless 1 Adjustable Gel Arms with Xanium Cover* 2 Adjustable Gel Arms with Textile Cover* 5 Fixed Arms with Urethane Cover 6 Fixed Gel Arms with Xanium Cover 7 Fixed Gel Arms with Matching Textile* *(Not available on Side Chair)	11	CYLINDER	— Standard 5" L Low 3.75" (Add \$25) T Tall 5" (Add \$35) F High 8" w/ 18" Foot Ring (Add \$105) R High 8" w/ 21" Foot Ring (Add \$145) E Return to Height 5" (Add \$40) <i>Note: Silver Trim Chairs ship with Polished cylinders. Black Trim chairs ship with Black cylinders. Return to Height (E) available in Black only.</i>
5	FRAME COLOR	B Black with Black Trim V Silver with Silver Trim L Silver with Black Trim A Polished Aluminum with Black Trim and Polished Base Caps* P Polished Aluminum with Silver Trim and Polished Base Caps* *(Add \$120 for Conference/Task Chair, \$80 for Side Chair)	12	CASTERS	— Standard 3" Casters for all surfaces G Glides
<i>Note: Frame color refers to all metal parts (back support, arm supports), Trim color refers to all plastic parts (base, back-rest frame, seat shell, etc.)</i>			13	FIRE PROOFING	— Standard Foams and Plastics C Cal 133 Approved Foams and Plastics (Add \$40 for Conference/Task chair, \$0 for Side Chair)
6	MESH STYLE	M Monofilament Stripe C Silver Check T Torque <i>See pages 17-18 and Textiles Kit for mesh descriptions and specifications.</i>	14	POLISHED BASE CAPS	— Standard Base to Match Frame Color A Polished Base Caps on Black or Silver Frame (Add \$40) <i>Note: Polished Base Caps are standard on Polished Aluminum frames.</i>
7	MESH COLOR	<i>See pages 17-18 and Textiles Kit for mesh color options and codes.</i>			

freedom® Features & Characteristics

With Freedom, the knobs, levers and locks of current-generation task chairs have been replaced by intelligent mechanisms that automatically support the body as it moves from task to task. By minimizing the need for manual controls, Freedom maximizes natural, spontaneous movement, which is essential for a healthy body and a comfortable day's work.

Freedom's many features can be enjoyed with virtually no effort.

Freedom exceeds known performance standards to such a degree that new ways of working become possible.



PHYSICAL CHARACTERISTICS

CUSHIONS

- Molded polyurethane foam cushions
- Armrests and optional seats have top layer of Technogel®
- Upholstered with a variety of materials customized to the unique form of the cushion

CUSHION PANS, ARMREST SUPPORTS, HEADREST FRAME

- Injection molded, structural, integral color plastics

EXTERNAL FRAME AND FIVE ARM BASE

- Die cast aluminum with fused plastic coating or polished aluminum finish

STORED ENERGY DEVICES

- Nitrogen charged gas cylinder for infinitely adjustable seat height
- Coil spring in the Self-Adjusting Recline mechanism
- Elastomer spring in the Pivoting Backrest

FOOT RING

- Chrome plated steel ring

STANDARD FEATURES

SELF-ADJUSTING RECLINE

- Intelligent counter-balance recline mechanism automatically provides the right amount of support through the full range of recline motion, regardless of user size and weight
- No tension springs to adjust
- No recline locks to set/release
- During recline, the angle between torso and legs opens up for better body function
- User maintains near constant eye level during recline

PIVOTING BACKREST

- Extra motion of the backrest during recline automatically adjusts to the changing needs of the spine
- Provides up to 1" additional lumbar support when needed

SYNCHRONIZED ARMRESTS

- Revolutionary armrests move in tandem to eliminate the dangers of uneven arm positioning
- Natural lift and release action for immediate repositioning without buttons or locks
- 6" range of vertical motion to accommodate all users and tasks
- Can be positioned below thigh-level for close table or desk work
- Attached to backrest so arms stay in same relation to body during recline
- Technogel® armpad for superb comfort

DYNAMIC HEADREST

- Position-sensitive headrest moves into place when you recline and out of the way when you sit upright
- 5" vertical adjustment to fit all users
- Moves in the natural arc of head/neck for perfect support through range of recline
- Contoured to cradle the head and neck in comfort

STANDARD CYLINDER

- Provides seat height range that accommodates 95% of the population

CONTOURED CUSHIONS

- Carefully sculpted to match body contours
- Increased contact area reduces pressure points
- Modular for easy replacement

BODY FIT

- Size adjustable to fit over 95% of the population
- Adjustments for Fit-to-Size:
 - Headrest: 5" vertical adjustment range
 - Seat Height: 5.33" adjustment range
 - Seat Depth: 2.25" adjustment range
 - Backrest / Lumbar Support Height: 3" adjustment range

HARD CASTERS

- 2.5" double-wheel casters for carpeted floors

OPTIONAL FEATURES

GEL SEAT CUSHION

- Non-degradable, non-compressible Technogel® layer on top of foam core
- Provides maximum pressure distribution
- Offers unmatched, long-term comfort

ADVANCED ARMRESTS

- Pivot at elbow for width adjustment
- Lockable in 5° increments
- Automatic unlock feature when positioned inward and user wishes to exit chair
- 1.25" longer than Standard Armrests for additional forearm support

LOW/HIGH CYLINDER HEIGHT

- Low range cylinder for very petite users
- High range cylinder for very tall users
- Extra high range cylinder (foot ring required) for use as high chair

FOOT RING

- Chrome finish
- Height adjustable

CASTER OPTIONS

- 2.5" soft double-wheel casters for hard floors
- Non-rolling glides for fixed location use
- 2.5" locking casters

FIRE PROOFING

- Cal 133 approved
- Fire proof barrier between textile and foam
- Fire retardant plastics

freedom® Options & Prices

TASK CHAIR



ARMRESTS

Armless



Standard Gel Armrests with Xanium Cover



Standard Gel Armrests with Matching Textile Cover



Advanced Gel Armrests with Xanium Cover



Advanced Gel Armrests with Matching Textile Cover

TASK CHAIR WITH HEADREST



Armless



Standard Gel Armrests with Xanium Cover



Standard Gel Armrests with Matching Textile Cover



Advanced Gel Armrests with Xanium Cover



Advanced Gel Armrests with Matching Textile Cover

FREEDOM SADDLE SEAT



Replacement Cushions

Seat (Foam)

Seat (Gel)

Back

Headrest

Armrest (Standard)

Armrest (Advanced)

Saddle



Retrofit Advanced Gel – Armrest Kit



CODE	TEXTILE 1	TEXTILE 2	TEXTILE 3	LEATHER 0	LEATHER 1	LEATHER 2
F110	\$955	\$1010	\$1100	\$1275	\$1730	\$2120
F111	\$1055	\$1110	\$1200	\$1375	\$1830	\$2220
F112	\$1070	\$1130	\$1225	\$1405	\$1865	\$2260
F113	\$1135	\$1190	\$1280	\$1455	\$1910	\$2300
F114	\$1150	\$1210	\$1305	\$1485	\$1945	\$2340
F210	\$1140	\$1205	\$1305	\$1510	\$1980	\$2370
F211	\$1240	\$1305	\$1405	\$1610	\$2080	\$2470
F212	\$1255	\$1325	\$1430	\$1640	\$2115	\$2510
F213	\$1320	\$1385	\$1485	\$1690	\$2160	\$2550
F214	\$1335	\$1405	\$1510	\$1720	\$2195	\$2590
F300	\$355	\$385	\$435	\$525	\$760	\$950
S 1 2 2 2 F	\$80	\$105	\$150	\$255	\$480	\$675
S 1 2 2 2 G	\$150	\$175	—	—	—	—
B 1 2 2 2 F	\$80	\$105	\$150	\$255	\$480	\$675
H 1 2 2 2 F	\$65	\$75	\$95	\$120	\$185	\$245
A 1 2 2 2 3	\$30 (Xanium) \$40 (fabric)	\$50	\$50	\$55	\$65	\$80
V 1 2 2 2 3	\$30 (Xanium) \$40 (fabric)	\$50	\$50	\$55	\$65	\$80
L 1 2 2 2	\$95	\$140	\$185	\$285	\$515	\$715
1 – Textile (W,V,D,U,X,N,Z,L,P,E) 2 – Cushion Color 3 – Armrest Position (L = Left, R = Right)						
KA 4 1 2 2 2	\$170 (Xanium) \$190 (fabric)	\$200	\$200	\$210	\$235	\$265

4 – Frame/Cushion Shell Color (G = Graphite, T = Titanium)

1 – Textile (W,V,D,U,X,N,Z,L,P) 2 – Cushion Color

freedom[®] Specifications

TASK CHAIR

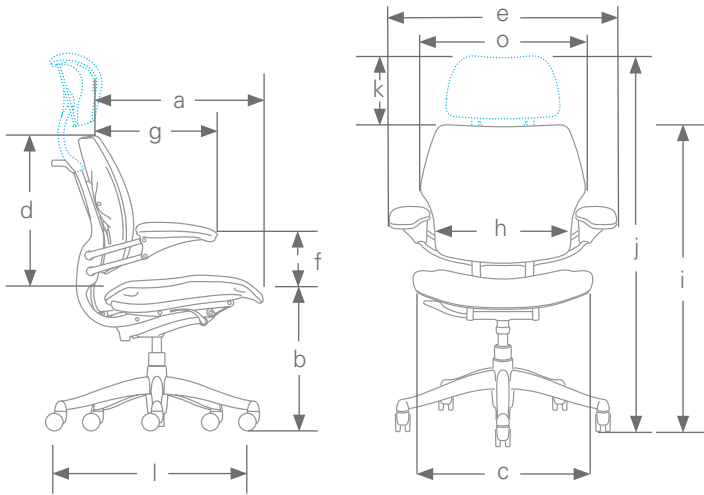

SCOPE OF USERS

- Standard chair fits over 95% of the office population
 - 5'0" Woman to 6'4" Man
 - 100 to 250 pounds
- Users outside the standard range can be accommodated by
 - Low or High Cylinder Height
 - Advanced Armrests

WEIGHT

- 35 lbs. Standard Chair
- 39 lbs. Chair with all options
- 19 lbs. Saddle with Foot Ring

BACKREST RECLINE

- 22° recline plus 7° backrest tilt

REFERENCE ANGLE BETWEEN SEAT AND BACK

- 100° to 129°

SADDLE SEAT

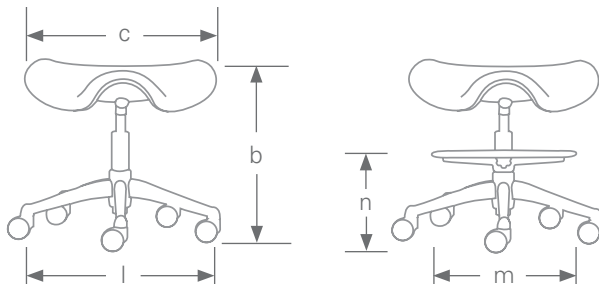

ADVANCED TASK ARMRESTS

- Horizontal angle change from elbow pivot point
 - 35° each armrest
 - Lockable in 5° increments

HEAD/NECK REST RADIAL MOTION (automatic motion during recline)

- 30°

LUMBAR SUPPORT INCREASE IN RECLINE

- 1"

CODE	DESCRIPTION	MEASUREMENT
a	seat depth <i>(from face of lumbar to front of seat)</i>	16.25" – 18.5"
b	seat height <i>(floor to compressed front center of seat cushion)</i>	16" – 21" standard chair 15.25" – 19" low chair 17" – 22.25" tall chair 20.5" – 28.5" high chair 17.5" – 22.75" standard saddle seat 20.25" – 28.25" high saddle seat 23" – 33" extra high saddle seat
c	seat width	21" chair 22" saddle seat
d	backrest height <i>(from seat cushion to top of backrest)</i> – adjustment range	18" – 21" 3" in .25" increments
e	backrest width	21"
f	armrest height <i>(compressed seat cushion to top of armrest)</i> – adjustment range	5" – 11" 6" in .33" increments
g	armrest length <i>(from face of lumbar to front of armrest)</i>	13" standard 14.25" advanced
h	distance between armrests	20" standard <i>(front inside edge)</i> 11.5" – 21.5" advanced <i>(front inside edge)</i>
i	height, task chair	33.5" – 41.5" standard chair 32.75" – 39.5" low chair 34.5" – 42.75" tall chair 38" – 49" high chair
j	height, task chair with headrest	43" – 53" standard chair 42.25" – 51" low chair 44" – 54.25" tall chair 47.5" – 60.5" high chair
k	headrest height adjustment range	5"
l	base diameter	25" chair, high or extra high saddle seat 22" standard saddle seat
m	foot ring diameter	18" or 21"
n	foot ring height adjustment <i>(from floor)</i>	10" – 16"
o		

freedom® Build Your Product Code



CHARACTER	CODE	DESCRIPTION	CHARACTER	CODE	DESCRIPTION
1	LINE	F Freedom	7	TEXTILE COLOR	See pages 17-18 and Textiles Kit for color options and codes
2	STYLE	1 Standard Task Chair 2 Task Chair with Headrest 3 Saddle Seat	8	GEL SEAT	— Standard Foam Seat Pan G Gel Seat (Add \$70) <i>Not available on Saddle Seat. Only available with Wave or Vellum Textiles.</i>
3	MECHANISM	1 Standard 0 Saddle Seat	9	CYLINDER	— Standard 5" L ¹ Low 3.75" (Add \$25) T Tall 5" (Add \$35) H ² High 8" (Add \$35) F High 8" w/ 18" Foot Ring (Add \$105) R High 8" w/ 21" Foot Ring (Add \$145) X ^{2,3} Extra High 10" w/ 18" Foot Ring (Add \$105) Z ^{2,3} Extra High 10" w/21" Foot Ring (Add \$145) <i>¹ Not available on Saddle Seat ² Only available on Saddle Seat ³ Requires Glides or Locking Casters.</i> <i>Note: Polished Aluminum chairs ship with Polished cylinders. Graphite and Titanium chairs ship with Black cylinders. Extra High (X,Z) available in Black only.</i>
4	ARMRESTS	0 Armless (<i>Required option for Saddle Seat</i>) 1 Gel Armrests with Xanium cover 2 Standard Gel Armrests with matching textile cover 3 Advanced Gel Armrests with Xanium cover 4 Advanced Gel Armrests with matching textile cover	10	CASTERS	— Standard Hard Casters S Soft Casters (Add \$20) G Glides (Add \$20) K Locking Casters (Add \$105)
5	FRAME COLOR	G Graphite T Titanium A Polished Aluminum with Graphite shells on cushions and armrests* M Polished Aluminum with Titanium shells on cushions and armrests* * (Add \$190 for Task Chair with Headrest, \$170 for Standard Task Chair, \$80 for Saddle Seat)	11	FIRE PROOFING	— Standard Foams and Plastics C Cal 133 approved foams and plastics (Add \$70 for Task Chair with Headrest, \$55 for Standard Task Chair, \$30 for Saddle Seat)
6	TEXTILE	W Wave Z Vicenza Leather V Vellum L Sabrina Leather D Sensuede P Prima Leather N Neptune U Spirit Millennium E Promessa	12	BASE COLOR	— Standard base will match frame color A Polished Aluminum Base on Graphite or Titanium Frame (Add \$80)

Textiles

TEXTILE

The cushions on all Humanscale chairs utilize advanced technology developed primarily for the sportswear and sporting goods industries. In a single step, a high-tech molding process combines the textile, Technogel® (standard on armrests, optional on seat cushions), foam and plastic support shell into a single, modular unit, which can be attached to our seating with four screws. Because of this advanced process, the textiles used on the cushions are as unique as the rest of the chair, and satisfy requirements more demanding than typical upholstery textiles.

WAVE

Textile Code: W **Textile Grade: 1**
Developed initially for sportswear, Wave responds to the unique form and production requirements of Humanscale seating. This four-way stretch fabric exceeds all contract interior testing requirements for heavy-duty upholstery. The colors of Wave are taken from the phenomenal hues found in nature.

Colors:

101	Black
102	Graphite
104	Smoke
201	Dark Brown
213	Rattan
402	Loden
415	Sage
502	Blue
507	Navy
601	Ultraviolet
714	Poppy
803	Cayenne

SENSUEDE

Textile Code: D **Textile Grade: 3**
Offering style and performance, Sensuede was developed to be the best and most luxurious engineered suede available. The silky feel is the result of recycled microfibers that are breathable, extra-strong and resistant to most stains and wrinkles.

Colors:

111	Ebony
115	Pewter
208	Chocolate
305	Goldenrod
406	Olive
411	Pear
413	Arbor
512	Denim
517	Persian
709	Pampas
712	Oxblood

NEPTUNE (For Saddle Seat Only)

Textile Code: N **Textile Grade: 2**
Named after the sea god of Roman mythology, this textile combines the benefits of an anti-bacterial and water-repellent textile with the soft feel of a cloth. It can be easily cleaned with a 1:10 bleach solution, making it ideal for healthcare and laboratory environments.

Colors:

101	Black
110	Dorsal
410	Moray
510	Regal
703	Lionfish

XANIUM (For Armrests Only)

Textile Code: X **Textile Grade: 1**
The material of choice for high-end bicycle seats, Xanium wears like steel but is extremely soft to the touch. It is a synthetic composite that can withstand extensive stress.

Colors:

101	Black
-----	-------

VELLUM

Textile Code: V **Textile Grade: 1**
Constructed of a simple weave using a blend of nylon, Cordura and elastic yarn, this textile offers a pleasing texture and extreme durability. Because of the Cordura content, this four-way stretch woven textile performs to the rigors of the most demanding contract environments. The color palette includes brights, classics, and a good selection of neutrals.

Colors:

101	Black
102	Graphite
106	Ash
114	Light Gray
202	Seal
211	Beech
212	Mahogany
404	Moss
407	Grass
414	Greenwood
507	Navy
607	Periwinkle
713	Pomegranate

SPIRIT MILLENNIUM

Textile Code: U **Textile Grade: 1**
An anti-microbial and wipeable textile manufactured by Naugahyde, this textile is designed for use in healthcare, education, hospitality and environments that require surfaces to be durable and easy to maintain. It passes healthcare testing, such as anti-microbial and cleanability tests, and meets fire code requirements.

Colors:

101	Black
112	Greystone
113	Gunmetal
210	Putty
304	Golden Corn
412	Artichoke
514	Dutch Blue
515	Wedgewood
516	Royal
608	Crocus
711	Raspberry
802	Mandarin Orange

PROMESSA

Textile Code: E **Textile Grade: 3**
This Ultraeather textile from Ultrafabrics is both wipeable and antimicrobial, ideally suited to healthcare, hospitality and industrial applications. Made without PVC, Promessa has a pebbled, highly textured finish and is available in 25 colors that will work beautifully in a wide variety of environments.

Colors:
See your Sales Representative for color sample cards.

Textiles

SPINNEYBECK LEATHER

VICENZA

Code: Z Leather Grade: 0

A lightly corrected, aniline dyed leather produced from European hides, Vicenza receives a special retannage which enriches the leather and tightens the grain. A breathable protective finish offers durability and comfort.

Colors:

101	Black
201	Dark Brown
214	Saddle
506	Night Blue

PRIMA

Code: P Leather Grade: 2

Prima signifies the ultimate in full grain leather. Old world craft combined with premium select raw material create a leather in a class by itself.

Colors:

101	Black
205	Bernini
511	Giotto
609	Bramante
708	Scarlatti

SABRINA

Code: L Leather Grade: 1

Sabrina is one of Spinneybeck's most popular full grain leathers, offering a smooth, tight grain and suppleness of hand. It is the favorite of those seeking an elegant, fine-grained leather for high traffic use.

Colors:

101	Black
203	Grey Beige
206	Bone
207	Nutmeg
408	Cat's Eye
508	Marine Blue
509	Water Sapphire
710	Rhubarb

MESH

These transparent textiles were created to provide optimal ergonomic support and comfort by melding strength, flexibility and resiliency. They surpass the performance criteria for contract seating textiles and meet a variety of environmental standards in both the U.S. and Europe. They have a pleasing hand that is also gentle on clothing.

MONOFILAMENT STRIPE

Mesh Code: M

Using only monofilament yarns that are thin and strong, a simple but classic stripe pattern is achieved through weave structure and yarn placement. This pattern has power stretch, giving this textile slight elasticity but terrific memory.

Colors:

11	Carbon
41	Green
51	Atlantic
81	Amber

TORQUE

Mesh Code: T

This proven weave construction gives the look of a solid yet translucent textile. Originally developed as a protective layer for motorcycle riders, Torque is woven with nylon, polyester and urethane yarns. It is both unique and durable.

Colors:

10	Black
13	Aluminum
31	Soleil
61	Lagoon

SILVER CHECK

Mesh Code: C

This unique translucent pattern is achieved using monofilament and a silver-plated yarn spun with polyester at its core. More than simply an aesthetic choice, the silver-plated yarn gives the textile flexibility and strength.

Colors:

12	Alloy
32	Topaz
62	Sapphire
71	Ruby

TEXTILE PURCHASE PROGRAM

All Humanscale Textiles (with the exception of Leather, Sensuede and Spirit Millennium) are available for purchase by the linear yard. The prices below are net (standard discounts do not apply.) A \$20 cut charge will apply to each order. Please see your Humanscale representative for more information.

Wave	\$35/yd (61" width)	Monofilament Stripe	\$60/yd (55" width)
Vellum	\$45/yd (50" width)	Silver Check	\$70/yd (61" width)
Neptune	\$42/yd (54" width)	Torque	\$70/yd (57" width)

CUSTOM COLORS

Textiles – Most Humanscale textiles are available in any customer-specified color. Delivery time frames for custom color orders will depend on color approval. A surcharge of \$200 will apply to custom color orders of 100 or more chairs, and a surcharge of \$350 will apply to custom color orders of less than 100 chairs. The following minimums are required for custom colors of each textile.

Vellum: 50-chair minimum (Freedom)
100-chair minimum (Liberty)

Wave: 175-chair minimum (Freedom)
350-chair minimum (Liberty)

Torque: 110-chair minimum

Non-Stocked Colors – Vicenza, Sabrina and Prima leathers, Sensuede, Spirit Millennium, and Promessa can be ordered in any color standard to these textile lines, even if it isn't stocked by Humanscale. Ordering any non-stocked color may impact the lead time for delivery. The list price upcharge for these non-stocked colors is as follows:

Vicenza, Sabrina, Prima: No upcharge

Sensuede: \$30 per chair (Freedom)
\$20 per chair (Liberty)

Spirit Millennium: \$25 per chair (Freedom)
\$15 per chair (Liberty)

Promessa: No upcharge



Humanscale Terms and Conditions

THE FOLLOWING TERMS & CONDITIONS APPLY TO ALL HUMANSCALE PRODUCTS.

TERMS OF PAYMENT

Seating: 50% deposit, balance Net 30 from date of shipment. 50% deposit is required for all new customer accounts. The processing of orders and/or shipment of orders placed may be delayed if the deposit is not received with the order or if customer's account is in "Past Due" status.

All other products: Balance Net 10 upon receipt of Humanscale's Invoice. Preferred Humanscale Dealer terms are Net 30. The processing of orders and/or shipment of orders placed may be delayed if Customer's account is in "Past Due" status.

CREDIT POLICY

All customers of Humanscale must complete a credit application, with current information, which must be signed by an owner or officer. A line of credit may be set by our Credit Department, however the basis for the line of credit may be changed or cancelled at our discretion and advance payment may be required. Any unpaid balance, upon which payments are not made according to the terms governing the sale, will be considered "Past Due" and will increase by a maximum of 2% per month, without forfeit of Humanscale's right to payment.

Any Customer who has failed to pay for goods delivered or services rendered in a timely manner shall be liable for all fees, expenses, disbursements, and charges (including all legal costs) incurred by Humanscale in collecting monies owed, as well as interest (at 24% per annum).

ORDER CHANGES/CANCELLATIONS

Seating: All changes to or cancellations of orders placed must be in writing and sent to Customer Service. Orders may be changed or cancelled without penalty if Humanscale is notified at least four (4) weeks before the scheduled ship-date. All order changes or cancellations made less than four (4) weeks before the scheduled ship-date will incur a minimum change/cancel fee of 15% of net. Irrespective of when notified, changes or cancellations are not binding upon Humanscale until Humanscale issues a written acknowledgment of the change or cancellation. Order changes are defined as the deletion of line items or a change in style, color, quantity or ship-to address. Order changes that result in a quantity reduction may be subject to an additional small order handling fee.

Under no circumstances will changes or cancellations be accepted on the Freedom Express program or on any custom fabric orders.

All other products: All changes to or cancellations of orders placed must be in writing and sent to Customer Service. Changes or cancellations are not binding upon Humanscale until Humanscale issues a written acknowledgment of the change or cancellation. Order changes are defined as the deletion of line items or a change in style, color, quantity, or ship-to address.

TAXES

Humanscale list prices do not include sales tax. Customer is responsible to remit all such tax. Humanscale requires a State Resale/Exemption Certification to be on file at its main office. Sales made without said Certificate will be charged the appropriate sales tax.

PRICES

All discounts and list prices are subject to change without notice. Prices are those in effect at the time of order entry. If the requested Shipment Date is more than 120 days after the Order Date, Humanscale reserves the right to price said order based on the published list price as of the Shipment Date.

SMALL ORDER HANDLING FEE

Orders of five (5) chairs or less will be assessed a handling fee of \$35 per chair.

SHIPPING AND DELIVERY

Seating: Seating orders, unless otherwise specified, will ship within 4 to 6 weeks from the date of order.

Minimum Order for Blanket Wrapped:

- No minimum within 75 miles of Piscataway, NJ
- 25 chairs minimum within 75- 200 miles of Piscataway, NJ
- 200 chairs minimum (a full truck load) if shipping more than 200 miles from Piscataway, NJ.

Unless otherwise contractually specified, Freedom and Liberty chairs will ship with the base and frame disassembled. Chair can be easily assembled in seconds without use of tools.

All other products: All packages are shipped via FedEx or common carrier. Standard Lead Time: 10 business days from receipt of order. Quick-Ship Lead Time: 48 hours from receipt of order of less than 100 units. Custom platform orders require 4 to 6 weeks. Standard shipping charges will be billed to Customer.

DELIVERY SHORTAGES

Product shortages must be noted at the time of delivery and reported to the carrier for correction. Claims against Humanscale for shortages, errors, etc. must be made in writing and within three (3) days of the date of delivery or Customer waives its right to make such a claim.

FREIGHT CLAIMS

Humanscale will file all F.O.B. destination claims. In order to receive credit, Customer agrees to cooperate and assist in the procedures set out by the carrier and Humanscale.

EXTERNAL DAMAGE

If the shipping container shows any external damage, Customer is instructed to refuse the product at time of delivery. If it is a multiple piece shipment, Customer may refuse only the damaged items. Humanscale will not issue full credit for returned product unless the following Action Steps are taken by Customer:

1. Note damage on the delivery receipt at time of delivery.
2. Refuse product at time of delivery.
3. Contact Humanscale customer service within 24 hours of the attempted delivery and advise them of the damage.
4. Enter a chargeable replacement order; credit will be issued after the disposition of damaged product is determined.

CONCEALED DAMAGE/LOSS

If Customer determines that there is internal damage, not visible at time of delivery, Customer will retain all packaging materials and take the following Action Steps within fifteen (15) calendar days from the date of delivery:

1. Request inspection by calling local freight carrier to report damage.
2. Retain merchandise in the original box.
3. Call your Humanscale customer service agent, provide order and product information.
4. Get a copy of the inspection report from carrier.
5. Enter a chargeable replacement order, credit will be issued after the disposition of damaged product is determined.

COMPLETE PURCHASE ORDER

Purchase orders must include the following information to process with Humanscale: Customer Information:, Sold To: Name/Address/Telephone/Fax/Contact Person, Ship To: Name/Address/Telephone/Fax/Contact Person, Order Date:, Requested Delivery Date:, Purchase Order Number:, Special Delivery Instructions:, Discount:, Quantity:, Full Model Numbers:, Total: List/Net

STORAGE

If a customer is unable to accept a scheduled product delivery, Humanscale, if notified before the product is placed with a carrier, shall store the product at Customer's expense. Humanscale shall invoice Customer for the product and monthly storage fees. If Customer is unable to accept a scheduled product upon delivery, customer shall be responsible for placing the product in storage and bears the risk of loss. However, payment of the balance due is per Humanscale's Terms of Payment above.

RETURN AUTHORIZATION FOR UNUSED PRODUCT

All Seating returns are subject to a twenty percent (20%) restocking fee and all other product returns are subject to a fifteen percent (15%) restocking fee. Customer must request a Return Authorization through the Humanscale Customer Service Department within 90 days of product receipt to return any unused product. If Humanscale agrees to restock the product, Customer must return it freight prepaid to Humanscale, F.O.B. the original shipping point or as otherwise instructed by Humanscale Customer Service. If product is returned without a Return Authorization, Humanscale will notify Customer of the unauthorized return and Customer must provide instructions for its disposition within one week thereafter. Failure of Customer to respond within one week will result in Humanscale's right to dispose of the product with no credit. Return Authorizations expire sixty (60) days after the date of issue. If the returned

product is not in resalable condition, Customer will not receive credit for the return. Customer must promptly provide a purchase order or other acceptance of fees/credit reduction as required.

*WARRANTY Limited Lifetime Warranty.

THE FOLLOWING WARRANTY IS IN LIEU OF ALL OTHER WARRANTIES EXPRESS OR IMPLIED, INCLUDING, BUT NOT LIMITED TO, THE IMPLIED WARRANTY OF MERCHANTABILITY AND FITNESS FOR A PARTICULAR PURPOSE AND ALL OTHER WARRANTIES ARISING FROM COURSE OF DEALING OR USAGE OF TRADE.

Humanscale offers a limited lifetime warranty on all products in this Price Guide, with the following exceptions:

No Warranty: Light Bulbs

1 Year: Whale Mouse

5 Years: Diffrient Light, Fabric/Cushions

8 Years: M5 Monitor Arm with Gas Cylinder

10 Years: All other Monitor Arms with Gas Cylinder components

Lifetime: All Other Products

This Warranty is applicable to the initial purchaser only and is non-transferable. Humanscale warrants that, at the time of Customer's acceptance, the product will be in good working order and will be free from defects in material and workmanship and does not apply to normal wear and tear or damage caused by accident, neglect, misuse or improper installation or operation. Humanscale will not be responsible for damage due to service, maintenance, modifications or tampering by anyone other than a Humanscale authorized representative. This Warranty is based upon a single 8-hour shift usage only and shall be pro-rated for double-shift or triple-shift usage. In the event a product is defective and Humanscale receives written notice of the defect within the Warranty period, Humanscale, at its option, will either repair or replace the defective product. This Warranty does not cover damage caused by a carrier or transportation of the product from one location to another, alterations made by owner, or Customer's Own Material.

LIMITATION OF LIABILITY

Purchaser's remedies set forth herein are exclusive and the liability of Humanscale with respect to the breach of this agreement or any contract entered into between the parties pursuant hereto shall not exceed the price of the product or part on which such liability is based. In no event will Humanscale be liable to purchasers for any special, collateral, incidental or consequential damages however caused, whether by Humanscale's negligence or otherwise.

The remedies provided above are the Purchaser's sole remedies for any failure of Humanscale to comply with its obligations regarding the workmanship of its products. Correction of any nonconformity in the manner and for the period of time provided shall constitute complete fulfillment of all liabilities of Humanscale, with respect to or arising out of the product furnished hereunder.

Seating Pricing and Specification Guide

Prices Effective January 2007

www.humanscale.com



Our Design Philosophy

At Humanscale, we believe the best designs in the world are based on purpose and function. If a design solves a functional problem as simply and elegantly as possible, the resulting form will be honest and timeless.

US Headquarters

11 East 26th Street
8th Floor
New York, NY 10010
212 725 4749
212 725 7545 fax

Customer Service

10 Inverness Drive East
Suite 100
Englewood, CO 80112
800 400 0625
303 858 9915
303 858 9916 fax
info@humanscale.com

European Headquarters

16 Britton Street
London EC1M 5SX
+44 207 566 7990
+44 207 566 7991 fax
info@humanscale.co.uk



Recognized by I.D. Magazine as one of the 10 "Best Companies" worldwide that help push design forward.

HS-SPG-107